

Datasheet for FUV45KW Series of FIVER



1. Specification of FUV45KW

Model	Lamp power (KW)	Input voltage (V)	Input Current (A)	Output voltage range (V)	Max output current (A)	Lamp voltage recommended (V)
220S/3KW	3	220	13.6	250-450	12	350
220T/3KW						
220V/4KW	4	220	18.2	250-450	15	350
220H/4KW						
220T/4KW	4	220	18.2	300-550	14	450
220S/4KW						
220T/5KW	5	220	22.7	350-550	14	500
220S/5KW						
380V/3KW	3	380	4.6	450-850	9	700
380V/4KW	4	380	6.1	500-850	9	700
380V/5KW	5	380	7.6	600-850	9	700
380V/5KWH	5	380	7.6	850-1100	8	900
380V/5.6KW	5.6	380	8.5	850-1100	8	950
380V/6KW	6	380	9.1	700-850	9	800
380V/6KWH	6	380	9.1	850-1100	8	950
380V/8KW	8	380	12.2	650-850	12	800
380V/8KWM	8	380	12.2	850-1100	10	1000
380V/8KWH	8	380	12.2	1100-1300	9	1200
380V/10KW	10	380	15.2	850-1300	13	1200
380V/10KWH	10	380	15.2	1300-1750	10	1450
380V/12KW	12	380	18.2	1000-1300	13	1200

380V/12KWM	12	380	18.2	1300-1750	10	1500
380V/12KWH	12	380	18.2	1750-2200	8	2000
380V/15KW	15	380	22.8	1100-1300	14	1200
380V/15KWM	15	380	22.8	1300-1500	12	1400
380V/15KWH	15	380	22.8	1500-1750	10	1700
380V/15KWB	15	380	22.8	1750-1950	9	1900
380V/15KWT	15	380	22.8	1950-2200	8.5	2100
380V/17KW	17	380	25.8	1300-1750	15	1700
380V/17KWM	17	380	25.8	1750-2200	12	2100
380V/20KW	20	380	30.4	1450-1750	15	1700
380V/20KWM	20	380	30.4	1750-2200	12	2100
380V/22KW	22	380	33.4	1900-2200	12	2150
380V/22KWM	22	380	33.4	2200-2400	11	2300
380V/22KWH	22	380	33.4	2400-2600	10	2500
380V/25KW	25	380	38	1800-2200	16	2150
380V/25KWM	25	380	38	2200-2600	13.5	2500
380V/28KW	28	380	42.5	2000-2200	16	2150
380V/28KWM	28	380	42.5	2200-2400	15	2300
380V/28KWB	28	380	42.5	2400-2600	13.5	2500
380V/28KWT	28	380	42.5	2600-2850	12.5	2750
380V/30KW	30	380	45.6	2000-2200	16	2150
380V/30KWM	30	380	45.6	2200-2400	15	2300
380V/30KWH	30	380	45.6	2400-2600	13.5	2500
380V/30KWB	30	380	45.6	2600-2850	12.5	2750
380V/30KWT	30	380	45.6	2850-3050	11.5	3000
380V/35KW	35	380	53.2	2400-2600	19	2500
380V/35KWM	35	380	53.2	2600-2850	18	2750
380V/35KWH	35	380	53.2	2850-3050	17	3000
380V/40KW	40	380	60.1	2400-2600	19	2500
380V/40KWM	40	380	60.1	2600-2850	18	2750
380V/40KWH	40	380	60.1	2850-3050	17	3000
380V/45KW	45	380	68.4	2850-3050	17	3000
380V/45KWM	45	380	68.4	3050-3300	16	3200
380V/45KWH	45	380	68.4	3300-3500	15	3400

Note: If input voltage is 480V, output voltage will be increased 20%.

2. Basic Specification

Input	Nominal voltage, frequency	220V 50/60Hz or 380V 50/60Hz
	Voltage range	-10%— +15%

	Digital input DI		Standard configuration 3 digital input DI1/DI2/DI3
	Analog input AI		Standard: 0~10V voltage input(AI) or 0~20mA current input(AI)
Output	Output voltage		380V: 450V-3500V, 220V: 200-240V
	Output frequency		8KHz-15KHz
	Digital output DO		Standard configuration 3 channel digital output DO1/DO2/DO3
	Analog output AO		2 channel 0~10V voltage output signal
	Relay contact output		Standard one set of AC 250V/2A normally open, normally closed contacts
Control method			Power vector control
Control characteristics	Power setting resolution		0.1KW
	Current limit		110% of the rated current of the lamp
	Voltage limit		110% of the rated voltage of the lamp
	RS485 communication		RS485 communication interface, which can control the operation and stop of the device, and reading of machine status
Typical function	Standby function		Can enter the standby power manually/automatically during downtime to save energy
	Lamp timer function		Can record lamp usage time
	Running function		External dry contact signal, RS485 communication signal control machine start and stop
Display	LCD keyboard display	Monitor status	Real-time monitoring of output power, output current, output voltage, module temperature, set power
		Alarm content	Latest 6 alarm codes, the last output power, output current, output voltage, DC bus voltage, module temperature and other values of the latest alarm
Protection/Alarm function			Phase loss, input over voltage, input under voltage, output over current, output short circuit, device over-temperature, temperature detection, output disconnection, internal memory damage, etc.
Environment	Ambient temperature		-10°C to +45°C (without freezing)
	Ambient humidity		Below 90% (no frosting)
	Surrounding environment		Indoor (no direct sunlight, no corrosion, flammable gas, no oil mist, dust, etc.)
	Altitude		Below 1000m

Structure	Protection class	IP20
	Cooling method	Forced air cooling

3. FUV45KW Dimensions:

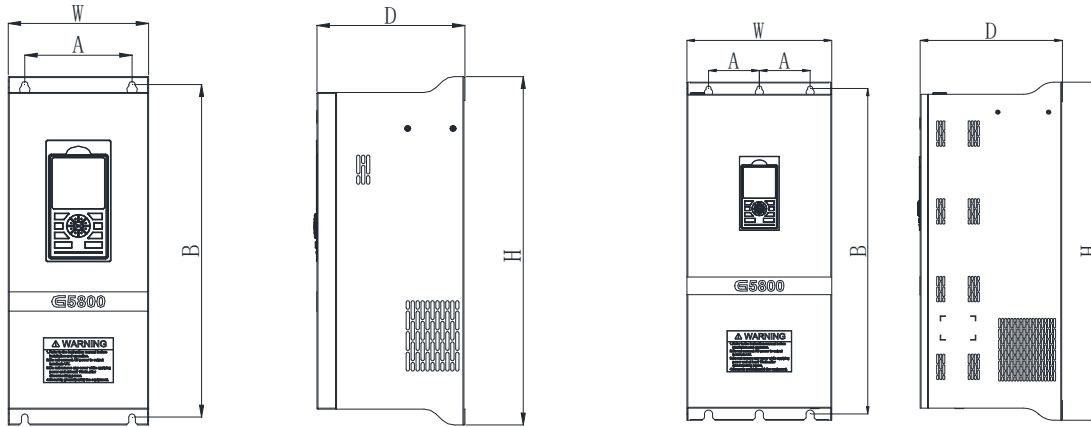

Applicable to 22KW and below model

Applicable to 25KW and above models

Power (KW)	Mounting hole (mm)		Dimension (mm)			Install aperture (mm)	Screw	Install method	N.W (KG)	G.W (KG)	Carton/ Poly wooden case size(mm)
	A	B	H	W	D						
220S/3KW	130	420	440	170	180	Φ8	M6	Wall mounted	9.8	10.7	570*240*250
220T/3KW											
3-6											
220V/4KW	134	503	525	170	230	Φ8	M6	Wall mounted	12.6	13.5	655*240*300
220S/4KW											
220T/4KW											
220H/4KW											
220T/5KW											
220S/5KW											
8											
10-15	125	598	620	185	230	Φ10	M8	17.4	18.9	715*320*345	
17-22	170	513	535	265	240	Φ10	M8	22.2	24.1	645*375*350	
25-30	100	674	700	285	280	Φ10	M8	39.2	43	810*395*390	
35-45 (old)	143	784	806	330	292	Φ10	M8	48	53	905*445*415	
35-45 (new)	143	764	790	330	300	Φ10	M8	48	53	905*445*415	

Note: all models > 22KW will be packed with poly wooden case to provide appropriate protection.

4. UV power supply control loop wiring diagram

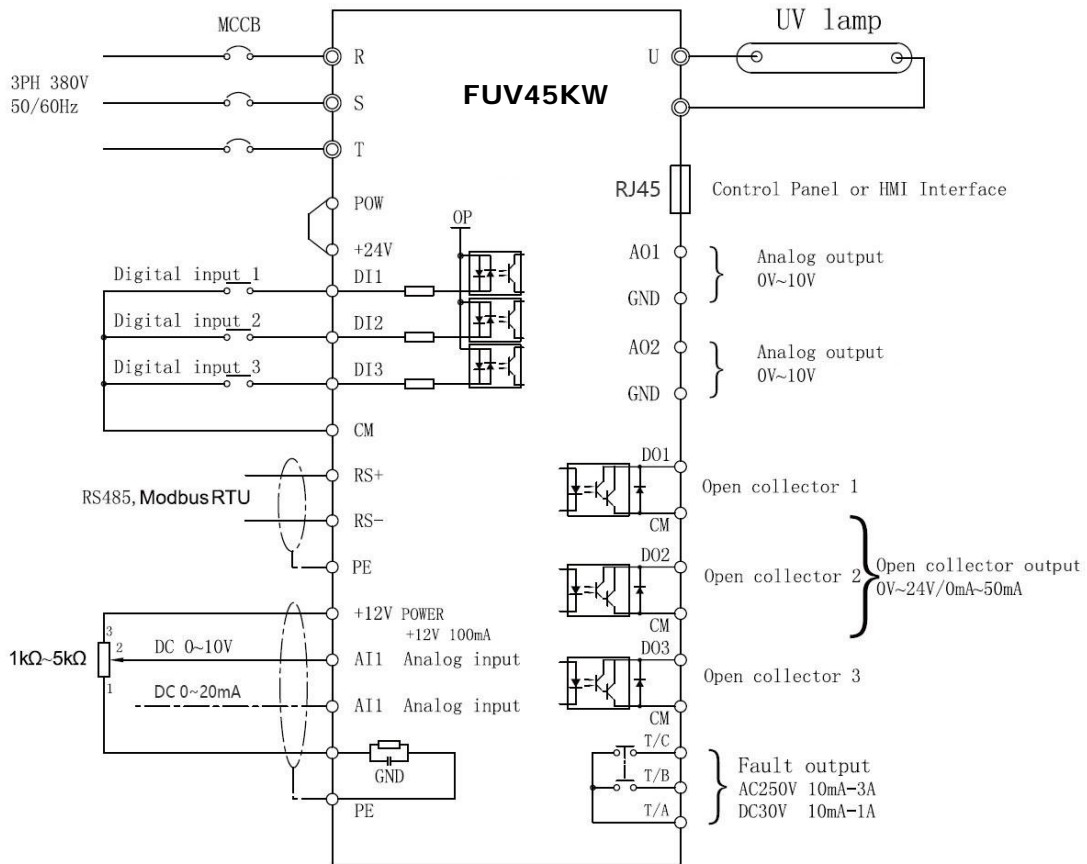

Note: "◎" Main circuit terminals, "○" Control circuit terminals

5. Installation requirements

- The installation space of UV electronic power supply requires as below:

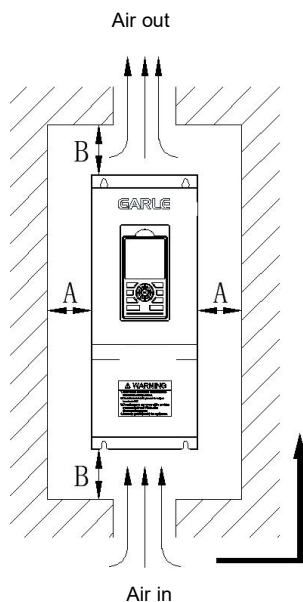

Power level	Size	
3.0KW~15KW	A≥20mm	B≥100mm
17KW~22KW	A≥20mm	B≥200mm
25KW~30KW	A≥50mm	B≥200mm
35KW-45KW	A≥100mm	B≥300mm

- The heat of EPS dissipates from the bottom part to the top. For more than 1 pcs EPS installation, Please have them installed side by side horizontally.

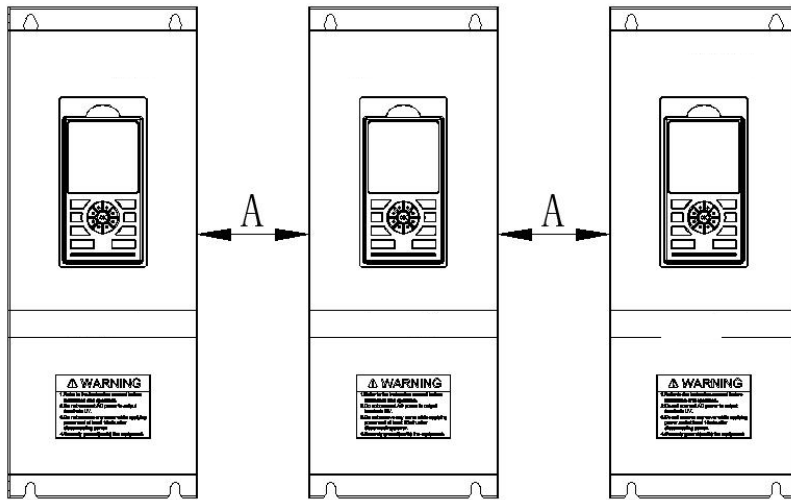

- Considering the heat dissipation performance, a mental plate is required to be installed as below If vertically installation is unavoidable:

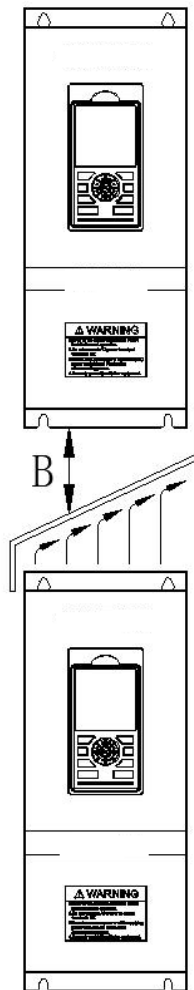

6. Operation panel (optional)

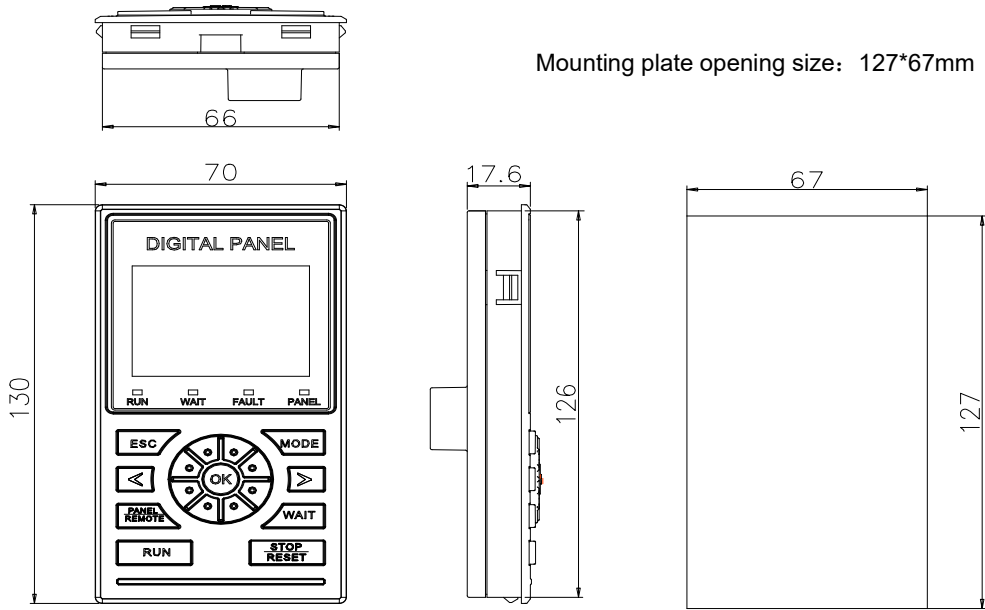

External LCD keyboard Shuttle keyboard Dimensions (unit: mm)

